



ENDURO[®] LF10 COATING

Improves Component Performance

PROVIDES LOW STICTION AND LOW FRICTION

Greene, Tweed's Enduro[®] LF10 Coating is a thin conformal, PTFE based coating that can be applied to a variety of components within manufacturing equipment including elastomeric, thermoplastic or metal components to enhance their performance. Enduro LF10 improves the performance by reducing the sticking force between component interfaces or wear caused by friction. The coating exhibits excellent adhesion, high purity and excellent conformality to thoroughly cover complex surface features. With deposition at low temperatures, it can be applied to many types of surface materials. For aqueous chemical environments, Enduro LF10 can also render surfaces from hydrophilic to hydrophobic. The coatings work well for both static and dynamic applications.

FEATURES & BENEFITS

- Continuous use at high temperatures equal to PTFE meets the thermal needs of most processes
- High conformality enables coating of complex surface features
- Friction and sticking force reduction extends lifetime of components, especially in dynamic and semi-dynamic applications
- Deposition occurs at low temperatures allowing coating of delicate structures and temperature sensitive materials
- Changeable surfaces from hydrophilic to hydrophobic enhance process equipment efficiencies

APPLICATIONS

- Reduced coefficient of friction for static and dynamic elastomeric seals
- Reduced sticking force (separation force) for seals including vacuum seals
- Reduced coefficient of friction for plastic and metal components
- Conversion of surface property from hydrophilic to hydrophobic

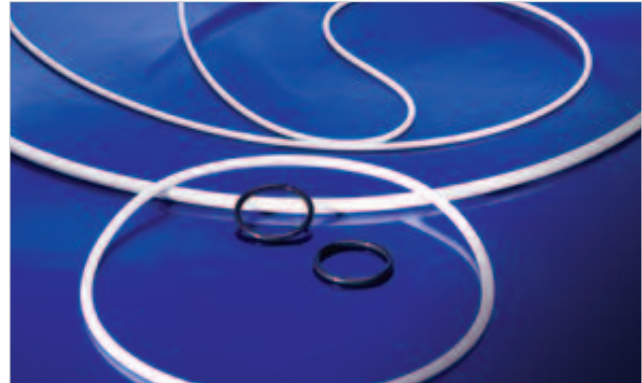

Enduro applied to Chemraz[®] seal

COATING THICKNESS

Enduro LF10 is applied at the micron level for:

- Solid substrates
- Flexible substrates (elastomers)

FRICTION FORCE ON CHEMRAZ® 505 AS-214 O-RINGS

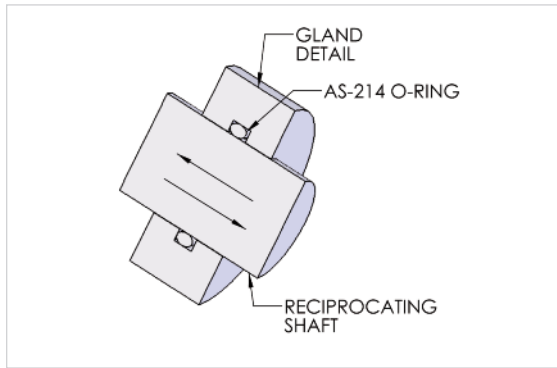
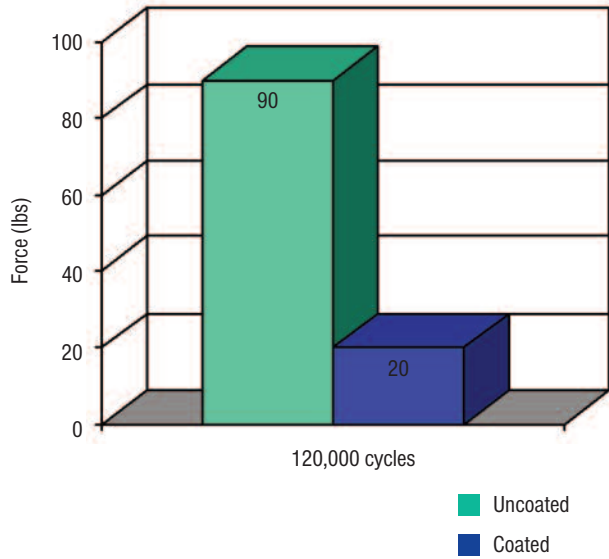

STICKING FORCE ON AS-214 O-RINGS

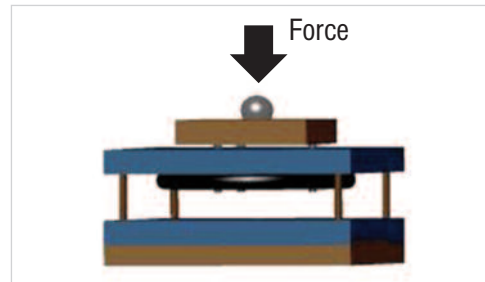
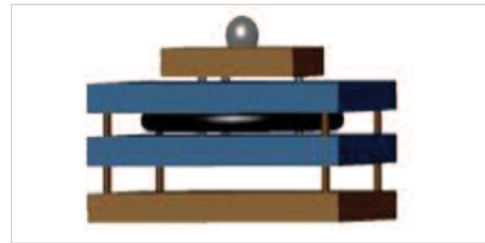
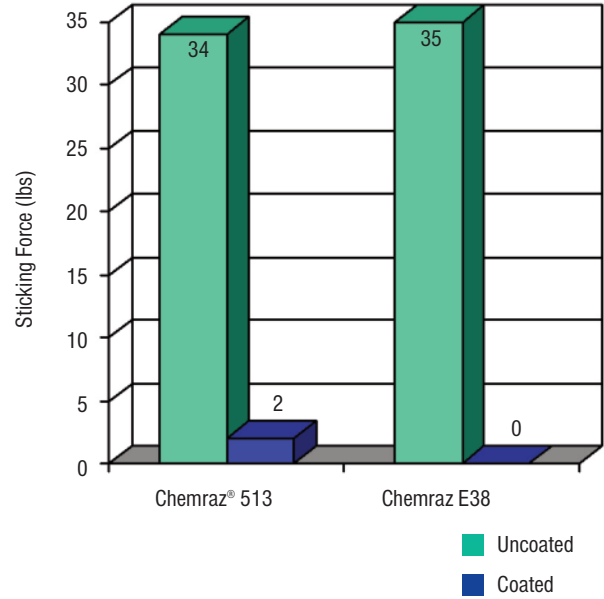

The illustrations above show an AS-214 O-ring compressed between SS plates. After the assembly is aged at the determined time and temperature, the fixture is removed from the oven and cooled to room temperature. The maximum force required to push the blue plates apart is recorded as the sticking force.

Contact Us